

**Facilities Study Report**  
**IR-662**  
**50MW Battery Energy Storage System**  
**132H - Spider Lake**

Prepared by  
Tim Leopold, P.Eng.

November 10, 2023

---

# Facilities Study Report

IR-662: BESS – 132H Spider Lake

---



## EXECUTIVE SUMMARY

This project (IR#662 – Spider Lake BESS) provides for the establishment of a 138 kV system interconnection at Nova Scotia Power Inc (NSPI) transmission substation 132H-Spider Lake for a 50MW Battery Energy Storage System (BESS) in Halifax County, Nova Scotia.

The Point of Interconnection (POI) is on NSPI’s 138kV bus B61 at 132H-Spider Lake substation. The designated Point of Change of Ownership (PCO) is at 138kV terminals of the 138kV – 35.5kV transformer serving the BESS facility. The POI and PCO are further clarified in the Interconnection Overview Drawing provided in Appendix B.

The scope of work associated with this interconnection will consist of a new 138kV breaker terminal at 132H – Spider Lake Substation, addition of revenue metering for the new interconnection, and modifications to existing protection and control schemes, Supervisory Control and Data Acquisition (SCADA), and telecommunications at 132H-Spider Lake.

The Interconnection Customer’s facilities will include a 138kV-34.5kV, 36/48/60 MVA autotransformer and associated cable interfaces to the proposed BESS. The BESS Facility will include a 34.5KV switchgear building including a 34.5kV circuit breaker, associated protection and control equipment, and cable interfaces as well as space for the transformer protection panel and communication equipment. The proposed BESS is rated 50MW at 200MWh with preliminary [REDACTED]

There are no Network Upgrades associated with this interconnection.

All interconnection facilities must meet NSPI’s Transmission System Interconnection Requirements (TSIR), version 1.1 dated February 25, 2021, as published on the NSPI OASIS site.

Protection and control upgrades are required to accommodate the addition of the BESS. Existing control panels will be modified to accommodate the new 138kV circuit breaker’s trip circuit monitors and breaker alarms in the 132H substation building. The Breaker Backup panel and the L-6044 line protection panels will be modified to accommodate the new breaker. NSPI will require space and unrestricted access in the BESS’s substation control building for the transformer protection panel and communications equipment.

Supervisory control will be provided via the existing RTU in the 132H-Spider Lake substation building. Telecommunication will be provided by existing facilities at 132H-Spider Lake.

The Revenue Class 138kV voltage and current transformers required for revenue metering will be supplied and installed by NSPI at the 132H-Spider Lake substation as per NSPI specification.

All system outages required to complete the interconnection work shall require advanced planning and coordination with the NSP System Operator.

The total estimated cost to construct the required Transmission Provider’s Interconnection Facilities is **\$1,349,603**. There are no Network Upgrades associated with this interconnection. A detailed cost estimate is provided in Appendix G. All cost estimates exclude allowance for funds used during construction (AFUDC) or any escalations due to timing of project execution. The customer will be responsible for paying NSPI for the actual costs associated with this project, be they higher or lower than the estimate provided herein, unless otherwise specified in the Generation Interconnection Agreement (GIA).

---

# Facilities Study Report

IR-662: BESS – 132H Spider Lake

---



The Interconnection Customer’s targeted commercial operation date is December 15, 2025, with first-power available by June 15, 2025. An overall preliminary project schedule is provided in Appendix H.

Part 2 of the System Impact Study (SIS) is still in progress and if any additional requirements are identified in the Part 2 Study, the Facilities Study (FAC) will be updated to reflect those additions as required.

---

# Facilities Study Report

IR-662: BESS – 132H Spider Lake

---



## Table of Contents

|   |           |
|---|-----------|
| <b>EXECUTIVE SUMMARY</b> .....  | <b>II</b> |
| <b>1.0 INTRODUCTION</b> .....   | <b>1</b>  |
| 1.1 PROJECT OWNERSHIP AND RESPONSIBILITIES.....                           | 1         |
| 1.2 ESTIMATED COST.....   | 2         |
| 1.3 PROJECT SCHEDULE .....  | 2         |
| <b>2.0 SCOPE OF WORK</b> .....  | <b>3</b>  |
| 2.1 INTERCONNECTION OVERVIEW.....   | 3         |
| 2.2 132H-B61 BUS TERMINAL.....  | 3         |
| 2.3 CUSTOMER’S INTERCONNECTION FACILITIES - BESS .....                    | 5         |
| 2.4 PROTECTION AND CONTROL .....  | 6         |
| 2.5 SUPERVISORY CONTROL AND DATA ACQUISITION / REMOTE TERMINAL UNIT ..... | 9         |
| 2.6 TELECOMMUNICATIONS .....  | 9         |
| 2.7 STATION SERVICE .....   | 9         |
| 2.8 REVENUE METERING .....  | 9         |
| 2.9 SCOPE OF WORK CATEGORIZATION .....                                    | 10        |
| <b>3.0 PERMITS, APPROVALS, AND STANDARDS</b> .....                        | <b>11</b> |
| <b>4.0 DESIGN AND CONSTRUCTION</b> .....                                  | <b>11</b> |
| <b>5.0 SCHEDULE MILESTONES</b> .....                                      | <b>12</b> |
| <b>6.0 COST ESTIMATE</b> .....  | <b>13</b> |
| <b>7.0 COMMISSIONING/OPERATIONS</b> .....                                 | <b>14</b> |
| <b>APPENDIX A – INTERCONNECTION FACILITIES STUDY AGREEMENT</b> .....      | <b>16</b> |
| <b>APPENDIX B – INTERCONNECTION OVERVIEW</b> .....                        | <b>17</b> |
| <b>APPENDIX C – 132H BESS DEVELOPMENTAL ONE LINE</b> .....                | <b>18</b> |
| <b>APPENDIX D – 132H-B61 BUS TAP CONFIGURATION</b> .....                  | <b>19</b> |
| <b>APPENDIX E – BESS INTERCONNECTION FACILITY ONE LINE (132H)</b> .....   | <b>20</b> |
| <b>APPENDIX F – BESS PRELIMINARY LAYOUT (132H)</b> .....                  | <b>21</b> |
| <b>APPENDIX G – COST ESTIMATE DETAILS</b> .....                           | <b>22</b> |
| <b>APPENDIX H – PRELIMINARY PROJECT SCHEDULE</b> .....                    | <b>23</b> |
| <b>APPENDIX I – REVENUE METERING</b> .....                                | <b>24</b> |
| <b>APPENDIX J– MINUTES OF FACILITIES STUDY REVIEW MEETING</b> .....       | <b>26</b> |

---

# Facilities Study Report

IR-662: BESS – 132H Spider Lake

---



## 1.0 INTRODUCTION

This Facilities Study Report is based on the System Impact Study Report (SIS) as identified below:

System Impact Study Report (Part 1)  
Report GIP-IR662-SIS-R3  
Dated June 29, 2023

The SIS describes the facilities and modifications required to the Nova Scotia transmission system to add a 50MW Battery Energy Storage System (BESS) at NSPI's 132H-Spider Lake substation. It also addresses short circuit, steady state, stability, power flow, and motor start analysis. It provides an overview of the scope of work to be completed and directions to this Facilities Study (FAC).

Part 2 of the SIS is still in progress and if any additional requirements are identified in the Part 2 Study, the FAC will be updated to reflect those additions as required.

The scope of work identified in the FAC outlines the anticipated work requirements for a conceptual level of engineering and design. Detailed design may identify additional requirements or modifications that were not anticipated or captured during the preliminary design phase.

### 1.1 Project Ownership and Responsibilities

Ownership, maintenance, and other commercial operation arrangements will be covered separately in a Generation Interconnection Agreement (GIA) between the Nova Scotia Power Inc (in its capacity as the Transmission Provider) and Nova Scotia Power Inc (in its capacity as the Interconnection Customer).

The Spider Lake BESS is being constructed at the existing 132H-Spider Lake substation and system device numbering for all additions will continue to be labelled under 132H.

The Point of Interconnection is the 138kV bus B61 at 132H-Spider Lake substation. Ownership of the infrastructure associated with the installation of a 50MW BESS at 132H-Spider Lake is based on the Point of Change of Ownership at the interface point between the 138kV side of the new 138kV – 34.5kV transformer and the 138kV terminal breaker 132H-661. An Interconnection Overview Diagram has been provided in Appendix B.

NSPI (Transmission Provider) will own the revenue metering located within the 132H-Spider Lake Substation.

All interconnection facilities must meet NSPI's Transmission System Interconnection Requirements (TSIR), version 1.1 dated February 25, 2021, as published on the NSPI OASIS site.

---

# Facilities Study Report

IR-662: BESS – 132H Spider Lake

---



## 1.2 Estimated Cost

The total estimated cost to construct the required Transmission Provider’s Interconnection Facilities is **\$1,349,603**. There are no Network Upgrades associated with this interconnection. The detailed cost estimates are provided in Appendix G. *All cost estimates exclude allowance for funds used during construction (AFUDC) or any escalations due to timing of project execution.*

The cost estimates are based on the scope of work outlined in Section 2.0 of this Facilities Study Report excluding any costs covered under the Customer Interconnection Facilities. The cost estimate provided in Appendix G are estimates only, based on 2023 budgetary dollars. The Interconnection Customer will be responsible for paying for the actual costs associated with this project, be it higher or lower than the estimate provided herein, unless otherwise specified in the Generation Interconnection Agreement (GIA).

The cost estimate in this report is valid for one hundred eighty (180) days.

The project cannot commence until the Interconnection Customer delivers to NSPI the balance of the cost estimate for the project in a form acceptable to NSPI (Transmission Provider), or as per the terms of the GIA.

## 1.3 Project Schedule

The estimated project duration includes all scope of work required for the transmission interconnection as outlined in Section 2.0.

The Interconnection Customer’s targeted commercial operation date is December 15, 2025, with first-power available by June 15, 2025.

An outline of major project milestones is provided in Section 5.0 and a preliminary project schedule outlining the major components of this project is provided in Appendix H.

---

# Facilities Study Report

IR-662: BESS – 132H Spider Lake

---



## 2.0 SCOPE OF WORK

The scope of this Facilities Study is limited to providing the necessary designs, equipment, labor, and services required to interconnect the new 50MW BESS at 132H-Spider Lake substation. The interconnection will be tapped to the 138kV Bus B61 at 132H-Spider Lake via a new 138kV breaker terminal.

This report will cover the following:

- The Transmission Provider's Interconnection Facilities (equipment located between the Point of Interconnection and the Point of Change of Ownership and within the Interconnection Customer's Substation).
- Overview of Interconnection Customer Interconnection Facilities

Note: there are no Network Upgrades associated with this interconnection request. The 138kV-34.5kV transformer is part of the Interconnection Customer's facilities located on the Interconnection Customer's side of the Point of Change of Ownership.

### 2.1 Interconnection Overview

An interconnection overview diagram of the 50 MW Spider Lake BESS interconnection is provided in Appendix B. The Point of Interconnection (POI) is the 138kV bus B61 at 132H-Spider Lake substation. The Point of Change of Ownership (PCO) is at the interface point between the 138kV side of the new 138kV – 34.5kV transformer and the 138kV terminal breaker 132H-661.

A Basic One Line diagram of the proposed 50MW BESS interconnection to 132H-Spider Lake substation is provided in Appendix C.

### 2.2 132H-B61 138kV Bus Terminal

A new 138kV breaker terminal will be established at 132H-Spider Lake on 138kV Bus B61 to accommodate the new BESS facility. A development plan view of the proposed layout is provided in Appendix D.

The scope of this work covers the Transmission Provider's Interconnection Facilities (TPIF) between the POI and the PCO.

#### 2.2.1 Structures and Foundations

All support structures and foundations shall comply with NSPI standard designs and requirements.

Concrete foundations and steel support structures will be installed for:

- 2 – 138kV high rigid bus supports
- 1 – 138kV low rigid bus supports

---

# Facilities Study Report



IR-662: BESS – 132H Spider Lake

---

- 1 – 138kV low disconnect support
  - 1 – 138V combined PT/CT support
- Concrete foundations only will be installed for:
- 1 – 138kV dead tank circuit breaker

## 2.2.2 Grounding, Conduit, and Cable Trench

The existing substation ground grid will be evaluated to ensure safe operation for updated fault levels and step/touch potentials. All new structures and equipment will be tied into the existing substation ground grid.

A concrete cable trench will be installed and extended from the existing substation cable trench to the new equipment. Conduits will be added as required to accommodate the new control cable additions.

## 2.2.3 Primary Equipment

All equipment shall conform with Nova Scotia Power standard equipment specifications.

New primary equipment will consist of:

- Circuit Breaker 132H-601
  - 145kV, 2000A, 31.5kA Dead Tank circuit breaker c/w 12/8/3/200-5A multi-ratio current transformers
  - As per NSPI Standard Circuit Breaker Specification SE-14.
- Disconnect 132H-661A.
  - 145kV, 2000A, 40kA, 650kV BIL vertical break disconnect with a manual operator.
  - As per NSPI Standard Specification SE-8 (Outdoor Air Switches)
- Revenue Class Combined Potential/Current Transformer 132H-CTPT61
  - Voltage: 145kV Rated; 80500V: 115/67.08 V & 115/67.08 V
  - Current: As specified during detailed design
  - Revenue Class Certified

## 2.3 Interconnection Customer Facilities - BESS

The layout and electrical design of the Interconnection Customer's substation and BESS Facility shall be the responsibility of the Interconnection Customer. A preliminary one-line of the Interconnection Customer's substation, as provided by the Interconnection Customer, is included in Appendix E. The scope of this work covers the interconnection requirements associated with the Interconnection Customer Interconnection Facilities on the BESS side of the PCO.

For this FAC, the location of the Interconnection Customer's 138kV-34.5kV transformer 132H-T61 is assumed to be within or directly adjacent the existing 132H fenced substation area. The location may differ once detailed design is completed. A preliminary layout of the substation facilities is provided in Appendix D.



---

# Facilities Study Report

IR-662: BESS – 132H Spider Lake

---



## 2.3.1 Structures and Foundations

All support structures and foundations shall comply with NSPI standard designs and requirements.

A concrete transformer pad shall be installed for the 138kV-34.5kV transformer 132H-T61. The foundation will be designed with NSPI's standard oil containment system including appropriately sized oil/water separation tanks.

## 2.3.2 Transformer for BESS

A 138kV – 34.5kV, 36/48/60 MVA transformer labelled 132H-T61 shall be installed to interface the BESS facility with the 138kV system bus 132H-B61. The transformer will be a Wye-Wye configuration with a buried 13.2 kV tertiary winding and a +/- 10% tap changer. Surge arresters will be provided on both the high and low voltage bushing terminals.

The primary terminals of the transformer will be open-air but the low voltage terminals will be enclosed for cable termination. The secondary terminals of the transformer will be connected to the BESS facility via 34.5kV primary cables concrete duct bank encased.

An oil containment system shall be installed for the transformer as noted in section 2.3.1.

## 2.3.3 50 MW Battery Energy Storage System (BESS)

A preliminary layout of the BESS facility is shown in Appendix F. The proposed BESS Facility includes a 34.5KV switchgear building including a 34.5kV circuit breaker, associated protection and control equipment, and cable interfaces. The proposed BESS is rated 50MW at 200MWh with preliminary design consisting of [REDACTED] inverters, and [REDACTED] parallel circuits.

All civil works, including site clearing, excavation, access roads, drainage, foundations, fencing, and ductwork associated with the BESS yard is part of the Interconnection Customer Facility's scope of work.

## 2.4 Protection and Control

Protection and control upgrades are required to accommodate the addition of the BESS. Existing control panels will be modified to accommodate the new 138 kV circuit breaker's trip circuit monitors and breaker alarms in the 132H substation building. The Breaker Backup panel and the L-6044 line protection panels will be modified to accommodate the new breaker.

NSPI will require space and unrestricted access in the BESS's substation control building for two transformer protection relays, and communications equipment. It is anticipated that this equipment can be housed in one single free-standing cabinet, but detailed design will be required before it can be confirmed if a second cabinet is required.

---

# Facilities Study Report



IR-662: BESS – 132H Spider Lake

---

The Interconnection Customer shall provide space and unrestricted access in the Interconnection Customer's substation control building for NSPI's protection, communications, and control equipment. The Interconnection Customer shall provide NSPI with all required SCADA points as defined during detailed design.

## 2.4.1 Transformer 132H-T61 Protection

At 132H-Spider Lake, transformer T61 protection will consist of redundant primary and secondary protection schemes. This protection shall be located in the BESS control building.

- The primary scheme line protection relay shall be a SEL-487E, receiving currents from the 138 kV breakers 132H-601 and 132H-606 and the 34.5 kV switchgear, and voltages from the 34.5 kV bus.
- The primary protection shall trip the 138 kV circuit breakers 132H-601 and 132H-606 via Trip Coil #1.
- The secondary scheme transformer protection relay shall be GE T60, receiving currents from the 138 kV breakers 132H-601 and 132H-606 and the transformer T61 LV bushing CTs, and voltages from the 34.5 kV bus.
- The secondary protection shall trip the 138 kV 132H-601 and 132H-606 breakers via Trip Coil #2.
- AC potentials for the primary and secondary protection schemes shall be supplied from separate secondary windings in the 34.5 kV bus Potential Transformers (PTs).
- AC currents for the primary and secondary protection schemes shall be supplied from separate Current Transformer (CT) cores.

## 2.4.2 Breaker Failure

- Breaker failure protection shall be provided for the new 138 kV circuit breaker 132H-601. This protection will be located in the existing 132H control building.
- Breaker Failure Initiate (BFI) must not be latched in the design. Breaker failure timer shall only run for (Trip active) AND (Breaker current above minimum pickup). The trip input to the BFI logic shall not be subject to a minimum trip duration.
- Note: Breaker Failure protection is referred to as Breaker Backup (BBU) in NSPI documentation. A Re-trip is referred to as "Early Trip."

## 2.4.3 138 kV Circuit Breaker Reclosing and Synchronizing

- Automatic reclosing shall be provided for the new 132H-601 breaker. Reclosing shall only be initiated by the L-6044 A and B protection. The 138 kV circuit breaker 132H-601 will only reclose under LIVE BUS/LIVE LINE conditions.
- Reclosing for breaker 132H-606 will be modified to remove Reclose Initiate signals from the L-6044 line protection. Reclosing shall only be initiated by the L-6055 A and B protection. The 138 kV circuit breaker 132H-606 will only reclose under LIVE BUS/LIVE LINE conditions.
- A sync check function shall be provided for all remote or local/auto close operations of breaker 132H-601. Local manual synchronizing capability shall also be provided.

---

# Facilities Study Report



IR-662: BESS – 132H Spider Lake

---

## 2.4.4 DC Supply for Protection

The Interconnection Customer shall provide dedicated 125V DC circuits and conduits (if required) from Interconnection Customer's substation DC station service distribution panel to supply the protection and control panel.

Primary and secondary protection schemes shall be supplied by separate DC breakers from the DC distribution panel.

## 2.4.5 Station Control and Communications

- An SEL-2240 Axion system shall be provided to act as a data concentrator, collecting the building, switchgear and protection alarms for forwarding to the 132H substation RTU/SER.
- Sequence of Events Recording (SER) functionality will be provided by the existing 132H substation SER.
- Communication between the 132H substation RTU and the BESS control system will use DNP3 protocol over serial fiber.
- Communication between the RTU/SER and the data concentrator shall be over serial fiber.
- A satellite clock shall be provided.
- A time signal shall be distributed to each measuring relay using either Precision Time Protocol (IEEE 1588-2008 or later) or IRIG-B time code over 50 ohm coaxial cable.
- Each protective relay shall assert an alarm to the SER in the event of a loss of satellite clock signal.
- If PTP is used for time distribution, the Ethernet switches used shall be capable of supporting PTP with the C37.238-2017 power system profile. The SEL-2741 SDN switch is preferred.
- In the event of a failure of the RTU, local manual operation of the 34.5 kV breakers shall be available from inside the IC control building.

## 2.4.6 Station Alarms

The following substation alarms will be provided to the local Sequence of Events Recorder (SER) and SCADA (unless otherwise noted):

1. Urgent (SCADA) time delayed & initiated by following SER points:
  - Station Service Failed
  - Battery Volts Low
  - Battery Charger Failed
  - Protection AC Potential Failed
  - Breaker Trip Circuit Failed
  - Fire Alarm Operated
  - Building High Temperature
  - Building Low Temperature
2. Non-Urgent (Scada) time delayed & initiated by following SER points:
  - Alternate Station Service Failed
  - Station Service Auto Transfer Operated
  - DC Supply(s) Grounded

---

# Facilities Study Report

IR-662: BESS – 132H Spider Lake

---



- Relay Time Sync Failed
- 3. Line 132H-T61 Primary Protection Operated (SER only)
- 4. Line 132H-T61 Secondary Protection Operated (SER only)
- 5. Local Control (Scada) initiated by following SER point:
  - Breaker 132H-601 Control Local (existing 132H control building only)
  - Breaker 132H-461 Control Local
  - Breaker 132H-411 Control Local
  - Breaker 132H-412 Control Local
  - Breaker 132H-413 Control Local
  - Breaker 132H-414 Control Local
  - Breaker 132H-415 Control Local
- 6. Breaker 132H-601 Closed (existing 132H control building only)
- 7. Breaker 132H-461 Closed
- 8. Breaker 132H-411 Closed
- 9. Breaker 132H-412 Closed
- 10. Breaker 132H-413 Closed
- 11. Breaker 132H-414 Closed
- 12. Breaker 132H-415 Closed
- 13. Breaker 132H-601 Urgent (Scada) initiated by following SER points:
  - Breaker 132H-601 SF6 Density Low (existing 132H control building only)
  - Breaker 132H-601 Motor Overload\* (existing 132H control building only)
  - Breaker Trip Circuit #1 Failed (existing 132H control building only)
  - Breaker Trip Circuit #2 Failed (existing 132H control building only)
- 14. Breaker 132H-601 Control Blocked (Scada) initiated by following SER point:
  - Breaker 132H-601 SF6 Control Blocked (existing 132H control building only)
- 15. Breaker Backup Lockout (Scada) initiated by following SER points:
  - Breaker 132H-601 BBU Lockout Operated (existing 132H control building only)
- 16. Breaker 132H-601 BBU Initiated & Early Trip Operated (existing 132H control building SER only)
- 17. Substation Entry
- 18. Protection/DC Fail (Scada) initiated by following SER points:
  - 132H-T61 Primary Protection Relay/DC Fail
  - 132H-T61 Secondary Protection Relay/DC Fail
  - 132H-411 Protection Relay/DC Fail
  - 132H-412 Protection Relay/DC Fail
  - 132H-413 Protection Relay/DC Fail
  - 132H-414 Protection Relay/DC Fail
  - 132H-415 Protection Relay/DC Fail

Note: These alarms may differ depending on the manufacturer of the breakers purchased and additional SCADA alarms may be required related to the BESS Control System.

---

# Facilities Study Report

IR-662: BESS – 132H Spider Lake

---



## 2.5 Supervisory Control and Data Acquisition / Remote Terminal Unit

Supervisory control will be provided via the SEL-3530 RTAC RTU in the existing 132H substation building.

## 2.6 Telecommunications

Telecommunication will be provided by existing facilities at 132H. Communication between the existing 132H substation building and the new BESS control building will be via serial fiber. This arrangement will effectively separate the new BESS system from the existing substation building for NERC CIP compliance.

## 2.7 Station Service

The Interconnection customer shall provide an alternate station service supply and auto transfer switch to maintain heat/lights/battery charger while transformer 132H-T61 is out of service.

## 2.8 Revenue Metering

A 138kV revenue metering system, owned by NSPI (Transmission Provider), shall be installed at the 132H-Spider Lake substation.

The 138kV revenue class current and voltage transformers will be supplied and installed by NSPI (Transmission Provider) complete with supporting structures, test switch, and meter base as per Nova Scotia Power metering standard STD 5.12 (attached as Appendix I: Revenue Metering).

The revenue metering class potential and current transformers shall not be embedded in any other piece of equipment and shall be certified by Measurement Canada for three element metering. Nova Scotia Power shall provide the technical specifications for the required current and voltage transformers to the Interconnection Customer.

Nova Scotia Power will install the revenue meter at the Interconnection Customer's substation once the commissioning is complete and the system is ready for energization.

---

# Facilities Study Report

IR-662: BESS – 132H Spider Lake

---



## 2.9 Scope of Work Categorization

In the event NSPI cannot meet the Interconnection Customer’s schedule expectation or as agreed in the terms of the Generation Interconnection Agreement (GIA), the Interconnection Customer may take responsibility for design, procurement, and construction activities associated with NSPI owned assets.

These design, procurement, and construction activities are limited to upgrades deemed to be ‘Transmission Providers Interconnection Facilities (TPIF)’ or ‘Stand Alone Network Upgrades’, defined as:

*Transmission Provider's Interconnection Facilities (TPIF) shall mean all facilities and equipment owned, controlled, or operated by the Transmission Provider from the Point of Change of Ownership to the Point of Interconnection as identified in Appendix A to the Standard Generator Interconnection and Operating Agreement, including any modifications, additions or upgrades to such facilities and equipment.*

*Network Upgrades (NU) shall mean the additions, modifications, and upgrades to the Transmission Provider's Transmission System required at or beyond the point at which the Interconnection Customer interconnects to the Transmission Provider's Transmission System to accommodate the interconnection of the Generating Facility to the Transmission Provider's Transmission System.*

IR-662 BESS Spider Lake interconnection requires TPIF but no Network Upgrades and all TPIF are non-stand-alone. Therefore, all TPIF associated with interconnection shall be performed by the Transmission Provider.

### 2.11.1 Network Upgrades Scope

There are no Network Upgrades required for this interconnection.

### 2.11.2 Transmission Provider Interconnection Facilities (TPIF) Scope

The TPIF scope of work includes:

- Addition of a 138kV breaker terminal
- Revenue Metering for the BESS terminal
- All associated protection, control, communication additions and modifications.

Interfaces and commissioning activities requiring joint collaboration shall be identified during the detailed design phase and prior to construction.

### 2.11.3 Customer’s Interconnection Facilities Scope

The Customer’s Interconnection Facilities are summarized in Section 2.3.

---

# Facilities Study Report

IR-662: BESS – 132H Spider Lake

---



## 3.0 PERMITS, APPROVALS, AND STANDARDS

The Interconnection Customer is responsible to obtain all permits and approvals required to construct the 50W BESS Facility at the 132H-Spider Lake substation location.

The installation will be subject to the review and approval by Nova Scotia Power (Transmission Provider) to ensure coordination of the Nova Scotia Power (Transmission Provider) and Interconnection Customer's scopes of work.

All equipment and installation shall comply with NSPI standard specifications and work practices.

## 4.0 DESIGN AND CONSTRUCTION

NSPI will be responsible for the design and engineering drawing production for all aspects of the scope of work from the Point of Interconnection to the Point of Change of Ownership unless otherwise specified and agreed in the Generation Interconnection Agreement (GIA). NSPI will also be responsible for the design of any other associated network upgrades or modifications identified in the Study Impact Study.

NSPI will be responsible for the procurement and construction of all aspects of the scope of work from the Point of Interconnection to the Point of Change of Ownership and any associated network upgrades unless otherwise specified in the Generation Interconnection Agreement (GIA).

The Interconnection Customer shall be responsible for the design, procurement, and construction of all facilities on the Interconnection Customer side of the Point of Change of Ownership.

The construction work associated with this interconnection will require planned outages to existing system components. Planned system outages must be coordinated with NSPI System Operations and will be restricted to opportunities when system reliability risks are acceptable.

# Facilities Study Report

IR-662: BESS – 132H Spider Lake



## 5.0 SCHEDULE MILESTONES

The Interconnection Customer’s targeted commercial operation date is December 15, 2025, with first-power available by June 15, 2025.

A preliminary project schedule outlining major components is provided in Appendix H.

A series of milestone target dates (listed below) were assumed based on optimistic timelines for the purpose of drafting a schedule for this Facilities Study. The in-service dates provided in this schedule are based on achieving these milestones. Missing any of these milestones increases the risk of meeting the proposed commercial operation date.

|   |                   |
|---|-------------------|
| Facilities Study Complete   | November, 2023    |
| Generation Interconnection Agreement Executed   | Q4 / 2023         |
| Detailed Design Start – 132H Interconnection  | Q4 / 2023         |
| Construction Start – 132H New 138kV Breaker Terminal  | Q3 / 2024         |
| Construction Start – 132H New 138kV-34.5kV Transformer Civil Works                              | Q3 / 2024         |
| 138kV Primary Equipment Delivery to Site  | Q4 / 2024         |
| 138kV-34.5kV Transformer Delivery to Site   | November, 2024    |
| New 138kV Breaker Terminal and Interconnection Customer Substation (132H) Construction Complete | Q2 / 2025         |
| Protection, Control, and Communications Modifications Complete                                  | Q2 / 2025         |
| First Power Available (132H)  | June 15, 2025     |
| Commercial Operation  | December 15, 2025 |



---

# Facilities Study Report

IR-662: BESS – 132H Spider Lake

---



## 6.0 COST ESTIMATE

The cost estimates have been produced using 2023 budgetary rates. They do not include a allowance for funds during construction (AFUDC) or any escalations due to timing of project execution.

The cost estimates are based on the conceptual design outlined in this report and should be considered as a class 3 accuracy level (-20% / +30%).

The cost estimates include project overheads based on NSPI's typical internal capital administration overhead allocation process. Overhead allocations may vary depending on how the project is executed.

There are no Network Upgrades associated with this interconnection request. *The cost estimate provided is only for the Transmission Provider Interconnection Facilities and does not include any costs associated with the Customer Interconnection Facilities.*

A contingency of 10% has been included in the estimates to account for unforeseen scope changes or supply chain issues.

Cost Estimate Summary:

| <b>Upgrade Component</b>   | <b>Cost Estimate</b> |
|--|----------------------|
| <b>Transmission Provider Interconnection Facilities (TPIF)</b>   |                      |
| New 138kV Breaker Terminal at 132H-Spider Lake Substation, Protection, Control, and Telecommunication equipment modifications, and addition of Revenue Metering for BESS interconnection | \$1,349,603          |
| <b>Total</b>   | <b>\$1,349,603</b>   |

A more detailed breakdown of each cost estimate is provided in Appendix G.

---

# Facilities Study Report

IR-662: BESS – 132H Spider Lake

---



## 7.0 COMMISSIONING / OPERATIONS

NSPI reserves the right to inspect all Interconnection Facilities identified in this study prior to connection to the NSPI Transmission System to ensure the facility design and construction will not adversely affect the reliability of the Transmission System. All Interconnection Facilities are subject to NSPI's review and acceptance of all testing and commissioning requirements and results. Construction, switching, testing, and commissioning schedules that affect the reliable and stable operation of the Transmission System shall be coordinated with the Nova Scotia Power System Operator.

All system outages required to complete the interconnection work shall require advanced planning and coordination with the Nova Scotia Power System Operator.

All interconnection facilities must meet NSPI's Transmission System Interconnection Requirements (TSIR), version 1.1 dated February 25, 2021, as published on the NSPI OASIS site.

---

# Facilities Study Report

IR-662: BESS – 132H Spider Lake

---



## Appendices

|   |                |
|---|----------------|
| <b>APPENDIX A – INTERCONNECTION FACILITIES STUDY AGREEMENT</b>    | <b>---16</b>   |
| <b>APPENDIX B – INTERCONNECTION OVERVIEW</b>                      | <b>-----17</b> |
| <b>APPENDIX C – 132H BESS DEVELOPMENTAL ONE LINE</b>              | <b>-----18</b> |
| <b>APPENDIX D – 132H-B61 BUS TAP CONFIGURATION</b>                | <b>-----19</b> |
| <b>APPENDIX E – BESS INTERCONNECTION FACILITY ONE LINE (132H)</b> | <b>----20</b>  |
| <b>APPENDIX F – BESS PRELIMINARY LAYOUT (132H)</b>                | <b>-----21</b> |
| <b>APPENDIX G – COST ESTIMATE DETAILS</b>                         | <b>-----22</b> |
| <b>APPENDIX H – PRELIMINARY PROJECT SCHEDULE</b>                  | <b>-----23</b> |
| <b>APPENDIX I – REVENUE METERING</b>                              | <b>-----24</b> |
| <b>APPENDIX J – MINUTES OF FACILITIES STUDY REVIEW MEETING</b>    | <b>-----26</b> |

---

# Facilities Study Report

IR-662: BESS – 132H Spider Lake

---



## **Appendix A – Interconnection Facilities Study Agreement**

(attachment 1)

# Facilities Study Report

IR-662: BESS – 132H Spider Lake



## Appendix B – Interconnection Overview

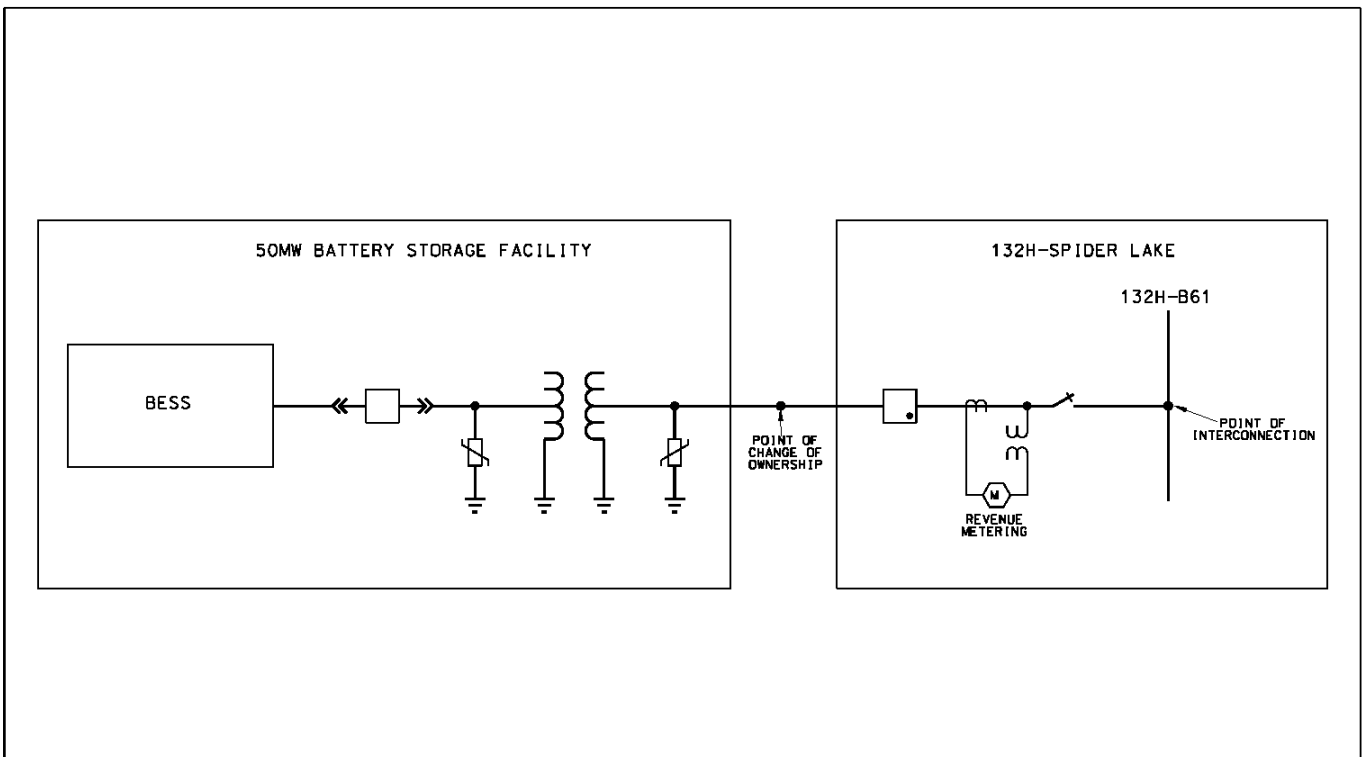

|                    |          |  |  |                        |           |   |
|--------------------|----------|--|--|------------------------|-----------|---|
| REFERENCE DRAWINGS | DWG. NO. |  |  | DEPARTMENTAL APPROVALS | SCALE NTS | <br>HALIFAX AREA<br>132H-SPIDER LAKE SUBSTATION<br>INTERCONNECTION OVERVIEW<br>IR-662 |
|                    |          |  |  | DESIGNED               | UNITS     |   |
|                    |          |  |  | DRAWN                  | TGL       |   |
|                    |          |  |  | CHECKED                | PEH       |   |
|                    |          |  |  | APPROVED               |           |   |
|                    |          |  |  | DATE                   |           |   |
|                    |          |  |  |                        | DATE      | 23-08-31  |
|                    |          |  |  |                        | W.O.      | SJK, E.T.C.H.1  |
|                    |          |  |  | SYSTEM-SOFTWARE-       | VERSION-  | DWG. NO.  |

# Facilities Study Report

IR-662: BESS – 132H Spider Lake



## Appendix C – 132H BESS Developmental One Line

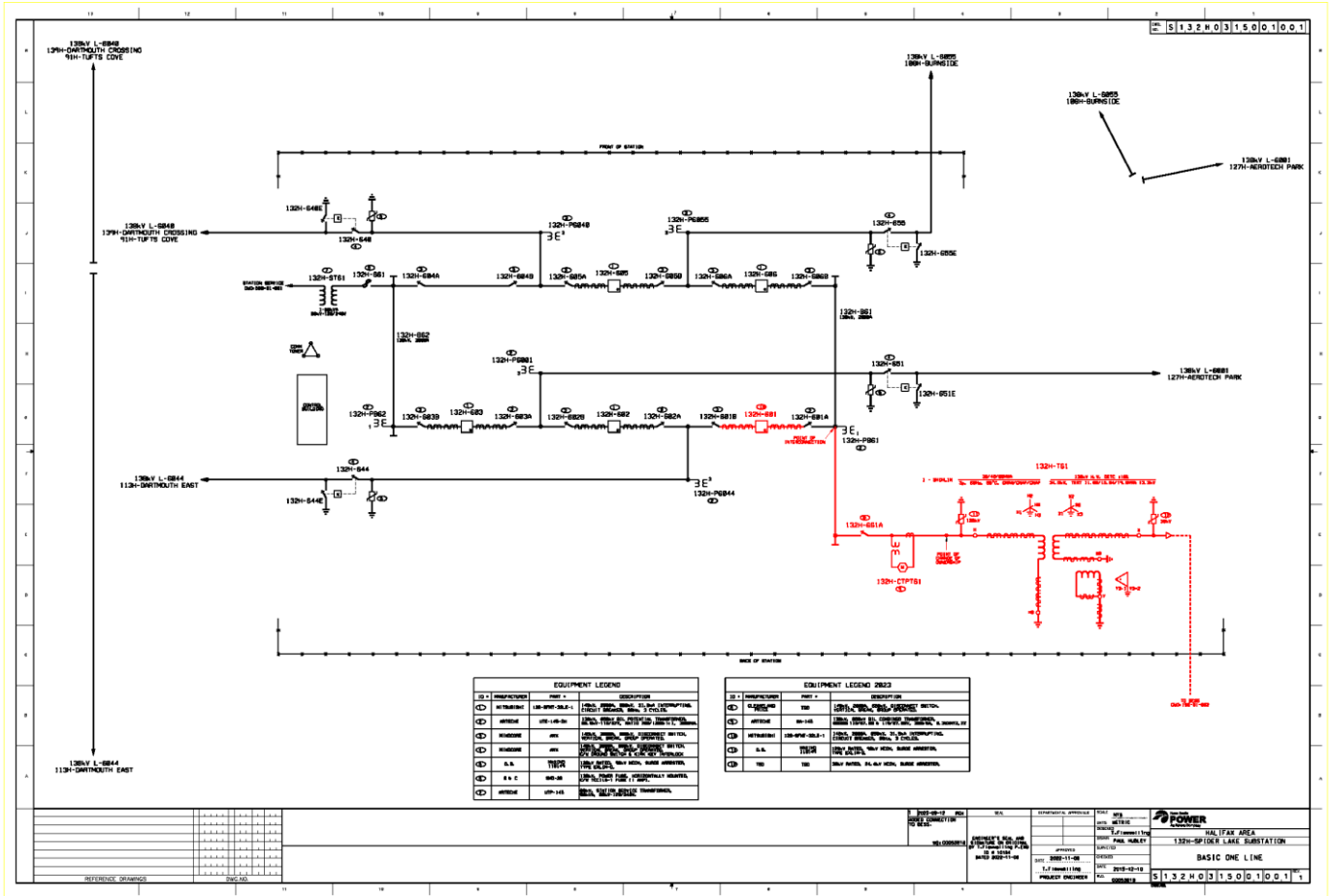



---

# Facilities Study Report

IR-662: BESS – 132H Spider Lake

---



## Appendix E – BESS INTERCONNECTION FACILITY ONE LINE (132H)

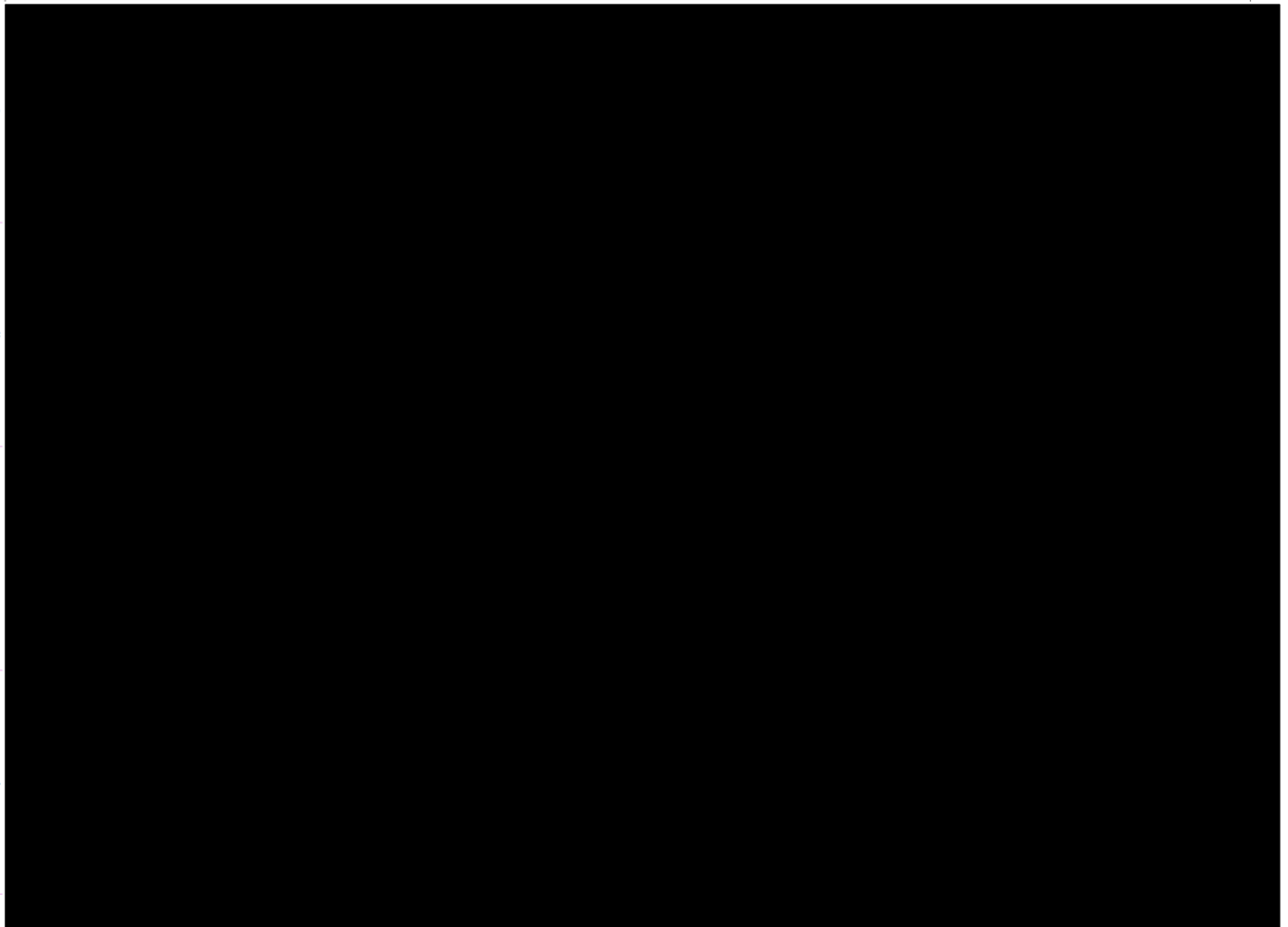



# Facilities Study Report

IR-662: BESS – 132H Spider Lake



## Appendix F – BESS Preliminary Layout (132H)

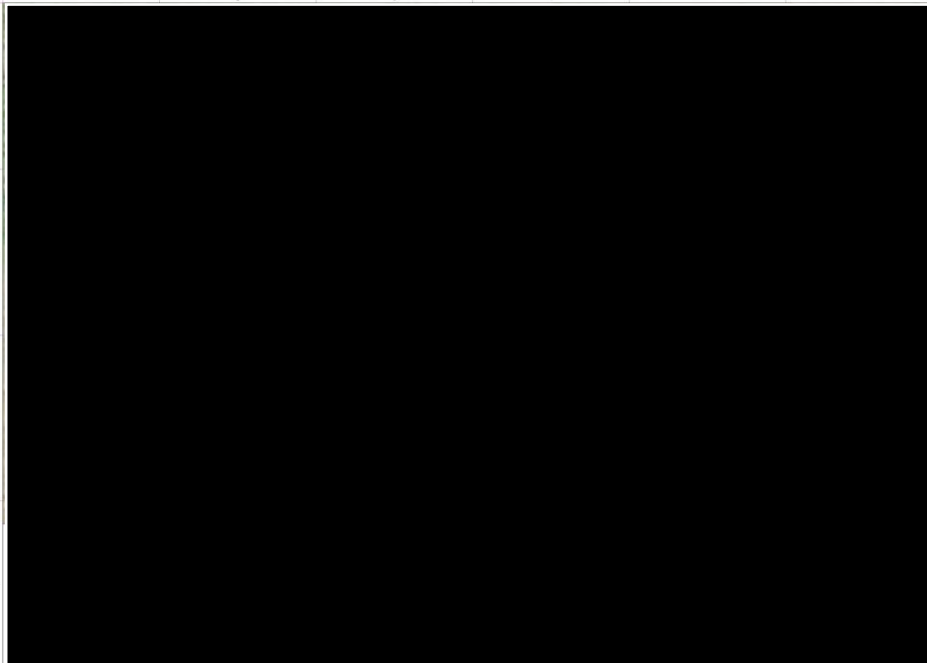
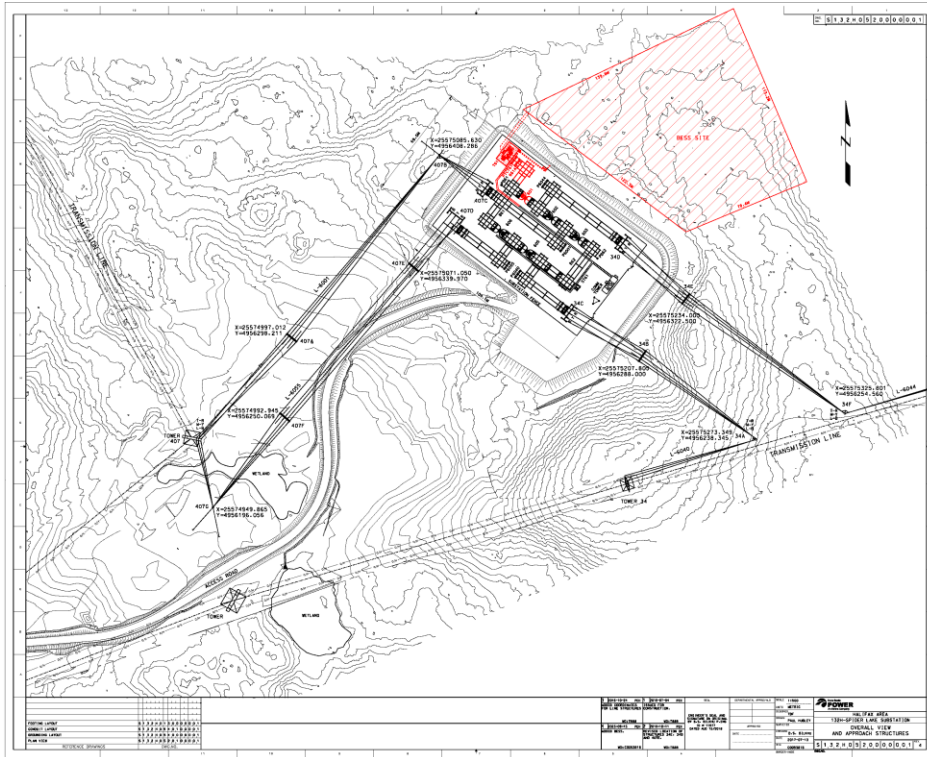

# Facilities Study Report

IR-662: BESS – 132H Spider Lake



## Appendix G – Cost Estimate Details

### Transmission Provider Interconnection Facilities (TPIF):

Note: This estimate includes the estimated costs for the TPIF only. This includes the addition of a 138kV breaker terminal, revenue metering, and a associated protection, control, communication additions and modifications.

This estimate does not include the new 138kV-34.5kV transformer, transformer foundation, or 34.5kV cable and ductbank to the BESS Facility which are part of the Customer Interconnection Facilities.

| 132H BESS Interconnection TPIF Only |   | CI Number:      |          |                |               |          |              |                |            |                  |
|-------------------------------------|---|-----------------|----------|----------------|---------------|----------|--------------|----------------|------------|------------------|
|                                     |   | Project Number: |          |                |               |          |              |                |            |                  |
|                                     |   | Cost Centre:    |          | 900            |               |          |              |                |            |                  |
| Activity                            | Accounts                                  | Labour          |          | Material       | Expenses      |          |              | Contracts      | Consulting | Totals           |
|                                     |   | Regular         | OT       |                | Travel        | OT Meals | Meals        |                |            |                  |
|                                     |   | 530050          | 530200   | 531400         | 530950        | 533410   | 533400       | 531550         | 532500     |                  |
| 003                                 | Buildings, Structures and Grounds         | 0               | 0        | 22,140         | 0             | 0        | 0            | 233,930        |            | 256,070          |
| 022                                 | Electrical Control Equipment              | 22,999          | 0        | 65,250         | 0             | 0        | 0            | 3,200          |            | 91,449           |
| 043                                 | Substation Devices                        | 14,026          | 0        | 293,865        | 0             | 0        | 0            | 33,200         |            | 341,091          |
| 061                                 | Telephone / Communications Equipment      | 10,726          | 0        | 0              | 0             | 0        | 0            | 0              |            | 10,726           |
| 085                                 | Design (i.e. Engineering)                 | 109,357         |          | 1,000          | 4,500         |          | 2,250        | 0              | 0          | 117,107          |
| 086                                 | Commissioning                             | 32,693          | 0        | 0              | 0             | 0        | 0            | 0              |            | 32,693           |
| 087                                 | Field Supervision and Operations          | 5,463           | 0        | 0              | 2,600         |          | 1,000        | 17,000         |            | 26,063           |
|                                     | <b>Sub-Total</b>                          | <b>197,175</b>  | <b>0</b> | <b>382,255</b> | <b>4,500</b>  | <b>0</b> | <b>2,250</b> | <b>287,330</b> | <b>0</b>   | <b>871,599</b>   |
| 085                                 | Contingency                               | 19,718          | 0        | 38,226         | 450           | 0        | 225          | 28,733         | 0          | 87,351           |
|                                     | <b>Sub-Total</b>                          | <b>216,893</b>  | <b>0</b> | <b>420,481</b> | <b>4,950</b>  | <b>0</b> | <b>2,475</b> | <b>316,063</b> | <b>0</b>   | <b>960,861</b>   |
| 005                                 | Vehicle Allocation (Labour & Engineering) |                 |          |                | 81,639        |          |              |                |            | 81,639           |
| 005                                 | Construction Overhead (Labour)            |                 |          |                |               |          |              | 162,311        |            | 162,311          |
| 005                                 | Construction Overhead (Eng. Labour)       |                 |          |                |               |          |              | 90,021         |            | 90,021           |
| 005                                 | Construction Overhead (Contracts)         |                 |          |                |               |          |              | 54,772         |            | 54,772           |
|                                     | <b>Sub-Total</b>                          |                 |          |                | <b>81,639</b> |          |              | <b>307,103</b> |            | <b>388,742</b>   |
|                                     | <b>Totals</b>                             | <b>216,893</b>  | <b>0</b> | <b>420,481</b> | <b>86,589</b> | <b>0</b> | <b>2,475</b> | <b>623,166</b> | <b>0</b>   | <b>1,349,603</b> |



# Facilities Study Report

IR-662: BESS – 132H Spider Lake



## Appendix I – Revenue Metering

NSPI Standards 5.7 and 5.12

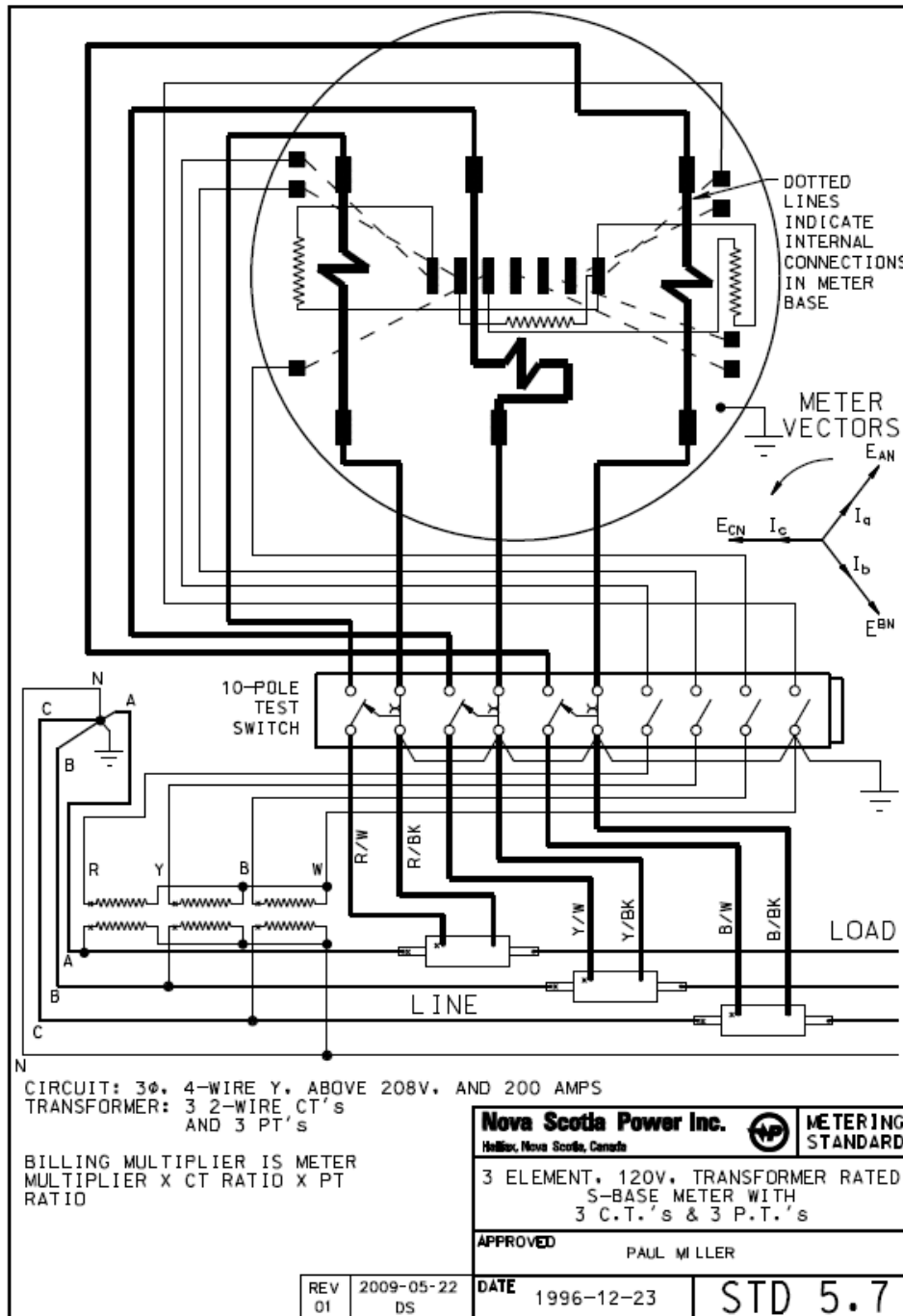

# Facilities Study Report

IR-662: BESS – 132H Spider Lake

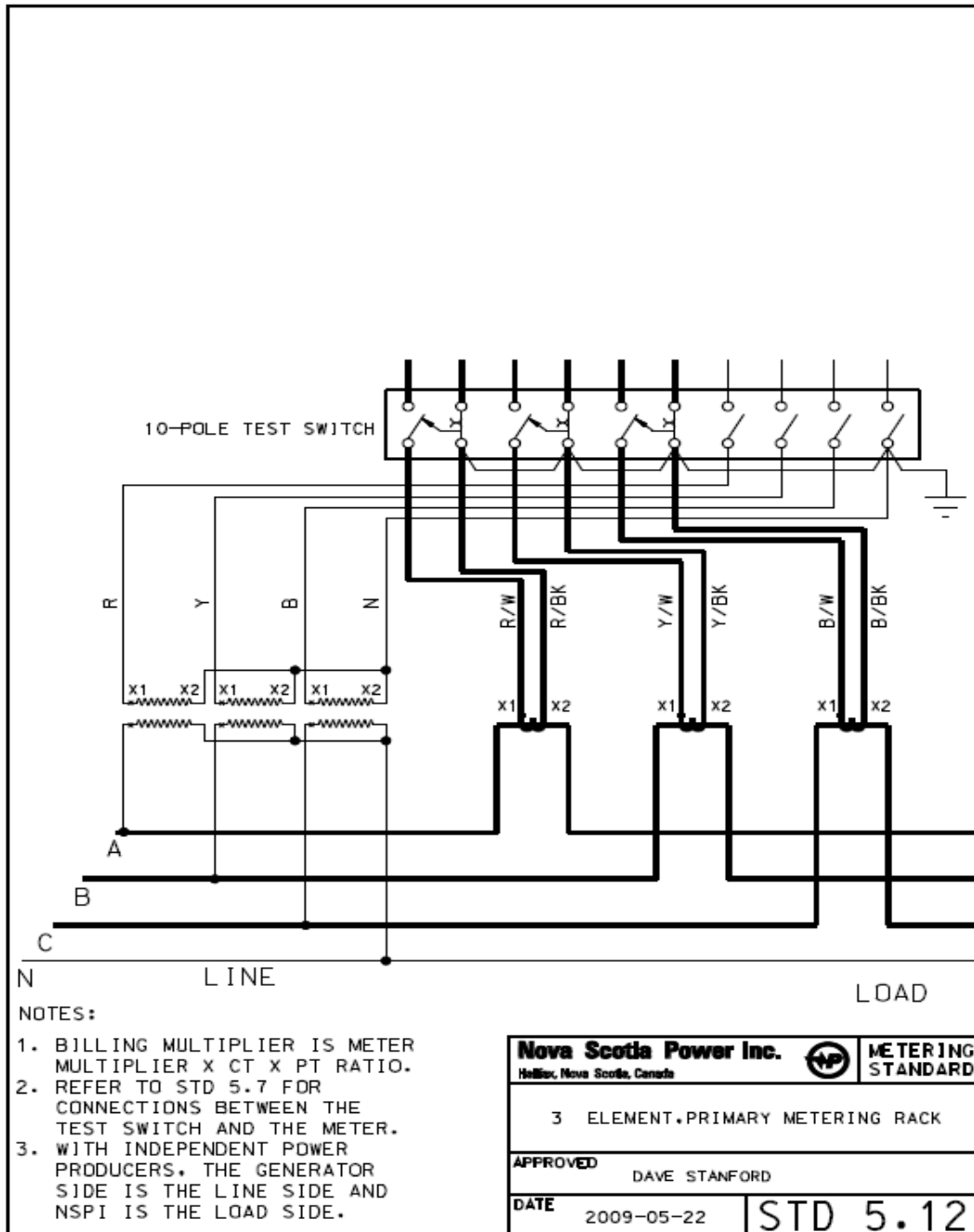

---

# Facilities Study Report

IR-662: BESS – 132H Spider Lake

---



## Appendix J – Minutes of Facilities Study Review Meeting

### Notes:

- Attendees: Debra McLellan, Elizabeth Dionne, Timothy Leopold, Mohit Agarwal
- Introductions: Date: November 30th 2023
- Review of questions provided by the Interconnection Customer (IC) on the draft Facilities Study (FAC): No questions submitted by IC
- Meeting Notes:
  - IC is working to negotiate the contract and added buffer so that they have [REDACTED] at COD and adding two additional containers to accommodate the degradation of batteries.
  - The reports will be public.
  - Waiting for confirmation if there is any confidential information that should be redacted from the report.
  - Provided high-level overview of transmission work for IR662 & IR664
  - No network upgrades are identified for any of these two IRs
  - More cost for Bridgewater interconnection is due to relocation of L-6002
  - The dates on FAC are based on what we know today like breakers are ordered, transformer are arriving in Aug 2024 for Bridgewater and Nov 2024 for Spider lake and these date can change in GIA and when GIA is executed.
  - SOW doesn't include Transformer and foundation work.
  - GIA will only be executed once we have all SIS is completed
  - Financial security is required 30 days in advance to begin any design/construction and this will be a milestone in GIA and will be negotiated to achieve COD
  - There is very little risk that any change in SIS would impact TPIF
  - FEAS identified some Network upgrade and is there a chance that Network upgrade would come back? They were identified in Feas as possibility and removed from SIS so we would go by the system impact study more so than the feasibility study.
  - Project size is capped 50MW
- Request from IC: Any information that is specific to the Battery vendor is considered Confidential at this time. This includes the number of inverters and transformers, site layout, Single lines, any Battery type or model information. Information that can be included is the specific SMA 3600 model as long as there is no reference to the number of units that will be use. This information is design specifically for this Battery Vendor